

OPERATOR'S MANUAL

PM05P-X-X-A02

INCLUDING: OPERATION, INSTALLATION & MAINTENANCE

RELEASED: 1-3-02
REVISED: 11-9-10
(REV. F)

1/2" DIAPHRAGM PUMP 1:1 RATIO, METALLIC



**READ THIS MANUAL CAREFULLY BEFORE INSTALLING,
OPERATING OR SERVICING THIS EQUIPMENT.**

It is the responsibility of the employer to place this information in the hands of the operator. Keep for future reference.

SERVICE KITS

Refer to Model Chart to match the pump material options.
637140-XX for Fluid Section Repair (see page 4).
637141 for Air Section Repair (see page 6).

PUMP DATA

Models	See Model Description Chart for "-XXX".
Pump Type	Air Operated Double Diaphragm.
Material	See Model Description Chart.
Weight	14.75 lbs (6.7 kgs)
Maximum Air Inlet Pressure	100 p.s.i.g. (6.9 bar)
Maximum Material Inlet Pressure	10 p.s.i.g. (0.69 bar)
Maximum Outlet Pressure	100 p.s.i.g. (6.9 bar)
Air Consumption	1 c.f.m. / gallon (approx.)
Maximum Flow Rate (flooded inlet)	13 g.p.m. (49.2 l.p.m.)
Displacement / Cycle @ 100 p.s.i.	0.040 g.p.m. (.15 l.p.m.)
Maximum Particle Size	3/32" dia. (2.4 mm)
Maximum Temperature Limits	
Polypropylene seats	175° F (79° C)
Stainless steel seats	200° F (93° C)
Dimensional Data	see page 8
Noise Level @ 70 p.s.i., 60 c.p.m.	71.1 db(A)Ⓢ

① The pump sound pressure levels published here have been updated to an Equivalent Continuous Sound Level (L_{Aeq}) to meet the intent of ANSI S1.13-1971, CAGI-PNEU-ROP S5.1 using four microphone locations.

NOTICE: All possible options are shown in the chart however certain combinations may not be recommended, consult a representative or the factory if you have questions concerning availability.

GENERAL DESCRIPTION

The ARO Diaphragm Pump offers high volume delivery even at low air pressure and a broad range of material compatibility options available. Refer to the model and option chart. ARO pumps feature stall resistant design, modular air motor / fluid sections.

Air operated double diaphragm pumps utilize a pressure differential in the air chambers to alternately create suction and positive fluid pressure in the fluid chambers, ball checks insure a positive flow of fluid.

Pump cycling will begin as air pressure is applied and it will continue to pump and keep up with the demand. It will build and maintain line pressure and will stop cycling once maximum line pressure is reached (dispensing device closed) and will resume pumping as needed.

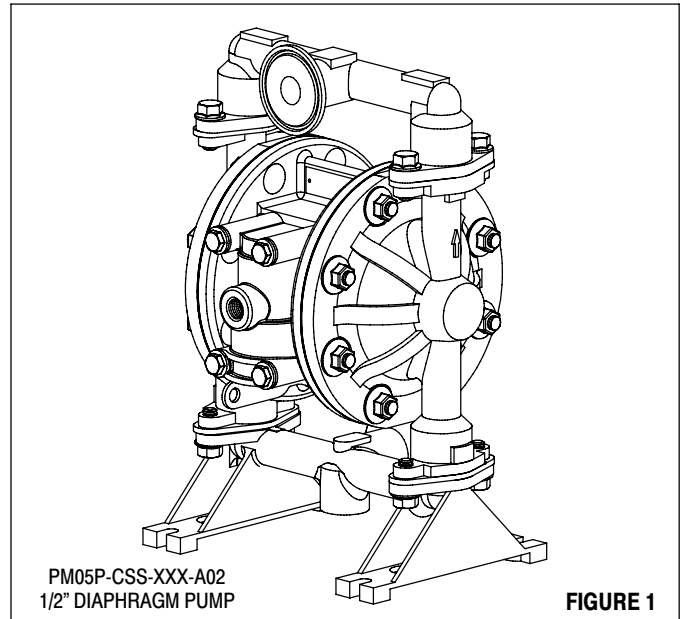

PM05P-CSS-XXX-A02
1/2" DIAPHRAGM PUMP

FIGURE 1

MODEL DESCRIPTION CHART

PM05 P - C S S - X X X - A02	
CENTER SECTION MATERIAL P - Polypropylene	
PORT C - Tri-Clamp	
FLUID CAPS & MANIFOLD MATERIAL S - Stainless Steel	
HARDWARE MATERIAL S - Stainless Steel	
SEAT MATERIAL P - Polypropylene S - 316 Stainless Steel	
BALL MATERIAL A - Santoprene® T - PTFE G - Nitrile V - Viton® S - Stainless Steel	
DIAPHRAGM MATERIAL A - Santoprene T - PTFE G - Nitrile	
FLUID SECTION SERVICE KIT SELECTION PM05P - CSS - X X X - A02	
EXAMPLE: MODEL # PM05P-CSS-SAA-A02 637140 - <input checked="" type="checkbox"/> <input checked="" type="checkbox"/> <input checked="" type="checkbox"/>	
FLUID SECTION SERVICE KIT # 637140-AA BALL <input type="checkbox"/> <input type="checkbox"/> <input type="checkbox"/> DIAPHRAGM <input type="checkbox"/>	

OPERATING AND SAFETY PRECAUTIONS

READ, UNDERSTAND AND FOLLOW THIS INFORMATION TO AVOID INJURY AND PROPERTY DAMAGE.



⚠ WARNING EXCESSIVE AIR PRESSURE. Can cause personal injury, pump damage or property damage.

- Do not exceed the maximum inlet air pressure as stated on the pump model plate.
- Be sure material hoses and other components are able to withstand fluid pressures developed by this pump. Check all hoses for damage or wear. Be certain dispensing device is clean and in proper working condition.

⚠ WARNING STATIC SPARK. Can cause explosion resulting in severe injury or death. Ground pump and pumping system.

- Sparks can ignite flammable material and vapors.
- The pumping system and object being sprayed must be grounded when it is pumping, flushing, recirculating or spraying flammable materials such as paints, solvents, lacquers, etc. or used in a location where surrounding atmosphere is conducive to spontaneous combustion. Ground the dispensing valve or device, containers, hoses and any object to which material is being pumped.
- Secure pump, connections and all contact points to avoid vibration and generation of contact or static spark.
- Consult local building codes and electrical codes for specific grounding requirements.
- After grounding, periodically verify continuity of electrical path to ground. Test with an ohmmeter from each component (e.g., hoses, pump, clamps, container, spray gun, etc.) to ground to insure continuity. Ohmmeter should show 0.1 ohms or less.
- Submerge the outlet hose end, dispensing valve or device in the material being dispensed if possible. (Avoid free streaming of material being dispensed.)
- Use hoses incorporating a static wire.
- Use proper ventilation.
- Keep inflammables away from heat, open flames and sparks.
- Keep containers closed when not in use.

⚠ WARNING Pump exhaust may contain contaminants. Can cause severe injury. Pipe exhaust away from work area and personnel.

- In the event of a diaphragm rupture material can be forced out of the air exhaust muffler.
- Pipe the exhaust to a safe remote location when pumping hazardous or inflammable materials.
- Use a grounded 3/8" min. i.d. hose between the pump and the muffler.

⚠ WARNING HAZARDOUS PRESSURE. Can result in serious injury or property damage. Do not service or clean pump, hoses or dispensing valve while the system is pressurized.

- Disconnect air supply line and relieve pressure from the system by opening dispensing valve or device and / or carefully and slowly loosening and removing outlet hose or piping from pump.

⚠ WARNING HAZARDOUS MATERIALS. Can cause serious injury or property damage. Do not attempt to return a pump to the factory or service center that contains hazardous material. Safe handling practices must comply with local and national laws and safety code requirements.

- Obtain Material Safety Data Sheets on all materials from the supplier for proper handling instructions.

⚠ WARNING EXPLOSION HAZARD. Models containing aluminum wetted parts cannot be used with III.-Trichloroethane, Methylene Chloride or other Halogenated Hydrocarbon solvents which may react and explode.

- Check pump motor section, fluid caps, manifolds and all wetted parts to assure compatibility before using with solvents of this type.

⚠ CAUTION Verify the chemical compatibility of the pump wetted parts and the substance being pumped, flushed or recirculated. Chemical compatibility may change with temperature and concentration of the chemical(s) within the substances being pumped, flushed or circulated. For specific fluid compatibility, consult the chemical manufacturer.

⚠ CAUTION Maximum temperatures are based on mechanical stress only. Certain chemicals will significantly reduce maximum safe operating temperature. Consult the chemical manufacturer for chemical compatibility and temperature limits. Refer to Pump Data on page 1 of this manual.

⚠ CAUTION Be certain all operators of this equipment have been trained for safe working practices, understand it's limitations, and wear safety goggles / equipment when required.

⚠ CAUTION Do not use the pump for the structural support of the piping system. Be certain the system components are properly supported to prevent stress on the pump parts.

- Suction and discharge connections should be flexible connections (such as hose), not rigid piped, and should be compatible with the substance being pumped.

⚠ CAUTION Prevent unnecessary damage to the pump. Do not allow pump to operate when out of material for long periods of time.

- Disconnect air line from pump when system sits idle for long periods of time.

⚠ CAUTION Use only genuine ARO replacement parts to assure compatible pressure rating and longest service life.

NOTICE Install the pump in the vertical position. The pump may not prime properly if the balls do not check by gravity upon start-up.

NOTICE Re-torque all fasteners before operation. Creep of housing and gasket materials may cause fasteners to loosen. Re-torque all fasteners to insure against fluid or air leakage.

NOTICE Replacement warning labels are available upon request: "Static Spark" PN \ 93616-1, "Diaphragm Rupture" PN \ 93122.

⚠ WARNING = Hazards or unsafe practices which could result in severe personal injury, death or substantial property damage.

⚠ CAUTION = Hazards or unsafe practices which could result in minor personal injury, product or property damage.

NOTICE = Important installation, operation or maintenance information.

AIR AND LUBE REQUIREMENTS

- A filter capable of filtering out particles larger than 50 microns should be used on the air supply. There is no lubrication required other than the “O” ring lubricant which is applied during assembly or repair.
- If lubricated air is present, make sure that it is compatible with the Nitrile “O” rings in the air motor section of the pump.

OPERATING INSTRUCTIONS

- Always flush the pump with a solvent compatible with the material being pumped if the material being pumped is subject to “setting up” when not in use for a period of time.
- Disconnect the air supply from the pump if it is to be inactive for a few hours.
- The outlet material volume is governed not only by the air supply but also by the material supply available at the inlet. The material supply tubing should not be too small or restrictive. Be sure not to use hose which might collapse.

- When the diaphragm pump is used in a forced-feed (flooded inlet) situation, it is recommended that a “Check Valve” be installed at the air inlet.
- Secure the diaphragm pump legs to a suitable surface to insure against damage by vibration.

MAINTENANCE

- Certain ARO “Smart Parts” are indicated which should be available for fast repair and reduction of down time.
- Provide a clean work surface to protect sensitive internal moving parts from contamination from dirt and foreign matter during service disassembly and reassembly.
- Keep good records of service activity and include pump in preventive maintenance program.
- Service Kits are available to service two separate Diaphragm Pump functions: 1. AIR SECTION, 2. FLUID SECTION. The Fluid Section is divided further to match typical active MATERIAL OPTIONS.

TYPICAL CROSS SECTION

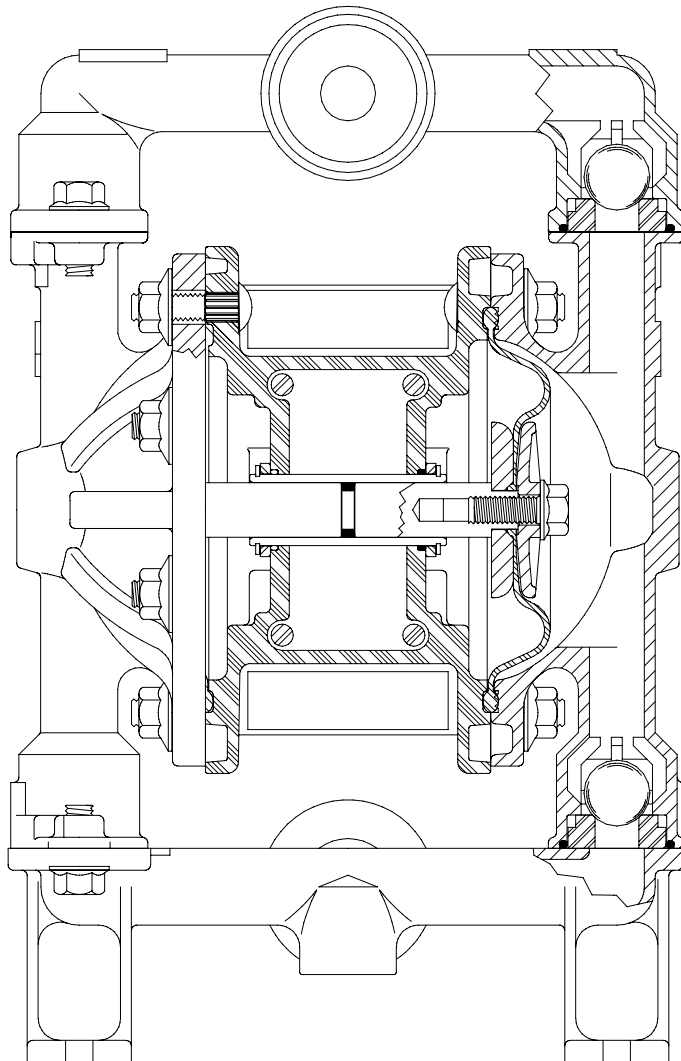

FIGURE 2

PARTS LIST / PM05P-X FLUID SECTION

★ **637140-XX FLUID SECTION SERVICE KITS** include: **BALLS** (See **BALL OPTION**, refer to **-XX** in chart below), **DIAPHRAGMS** (See **DIAPHRAGM OPTION**, refer to **-XX** in chart below), plus “O” ring items: 2, 19 and 93706-1 Key-Lube® grease.

SEAT OPTIONS PM05P-XXX-XXX-A02			BALL OPTIONS PM05P-XXX-XXX-A02				DIAPHRAGM OPTIONS PM05P-XXX-XXX-A02				
“21”			★ “22”		★ “19”		★ SERVICE KIT		★ “7” / “8”		
-XXX	Seat (4)	[Mtl]	-XXX	Ball (4) (3/4" diameter)	[Mtl]	“O” Ring (4) (3/32" x 1-5/16" o.d.)	[Mtl]	-XX = (Ball) -XX = (Diaphragm)	Diaphragm (2)	[Mtl]	
-PXX	93098-10	[P]	-XAX	93100-E	[SP]	93763	[E]	-XXA	637140-XA	93465	[SP]
-SXX	93409-1	[SS]	-XGX	93100-2	[B]	Y325-122	[B]	-XXG	637140-XG	93465-G	[B]
			-XSX	93410-1	[SS]	93764	[F]	-XXT	637140-XT	93111 / 93465	[T/SP]
			-XTX	93100-4	[T]	93265	[T]				
			-XVX	93100-3	[V]	Y327-122	[V]				

COMMON PARTS

ITEM	DESCRIPTION (Size in inches)	Qty	Part No.	[Mtl]	ITEM	DESCRIPTION (Size in inches)	Qty	Part No.	[Mtl]
<input type="checkbox"/> 1	Connecting Rod	(1)	93084	[SS]	26	Flange Screw (5/16" - 18 x 3/4")	(8)	94628	[SS]
★ 2	“O” Ring (3/32" x 5/8" o.d.)	(1)	Y325-111	[B]	43	Ground Strap	(1)	92956-1	[SS]
5	Diaphragm Washer (2" o.d.)	(2)	94645	[GFN]	57	Ground Kit Assembly (not shown)	(1)	66885-1	
<input type="checkbox"/> 6	Diaphragm Washer (2" o.d.)	(2)	94622	[SS]	60	Manifold, Inlet (Bottom)	(1)	95645	[SS]
14	Flange Screw (5/16" - 18 x 3/4")	(2)	94628	[SS]	61	Manifold, Outlet (Top)	(1)	95644	[SS]
15	Fluid Cap	(2)	95646	[SS]	62	Flange Nut (5/16" - 18)	(16)	93886	[SS]

“Smart Parts” keep these items on hand in addition to the Service Kits for fast repair and reduction of down time.

MATERIAL CODE	
[B]	Nitrile
[E]	E.P.R.
[F]	Flouraz®
[GFN]	Glass Filled Nylon
[P]	Polypropylene
[SP]	Santoprene
[SS]	Stainless Steel
[T]	PTFE
[V]	Viton

PARTS LIST / PM05P-X FLUID SECTION

COLOR CODE		
MATERIAL	DIAPHRAGM COLOR	BALL COLOR
NITRILE	BLACK	RED (+)
SANTOPRENE	TAN	TAN
TFE	WHITE	WHITE
VITON	N / A	YELLOW (+)
	(-) STRIPE	(+) DOT

FOR THE
AIR MOTOR SECTION
SEE PAGES 6 & 7

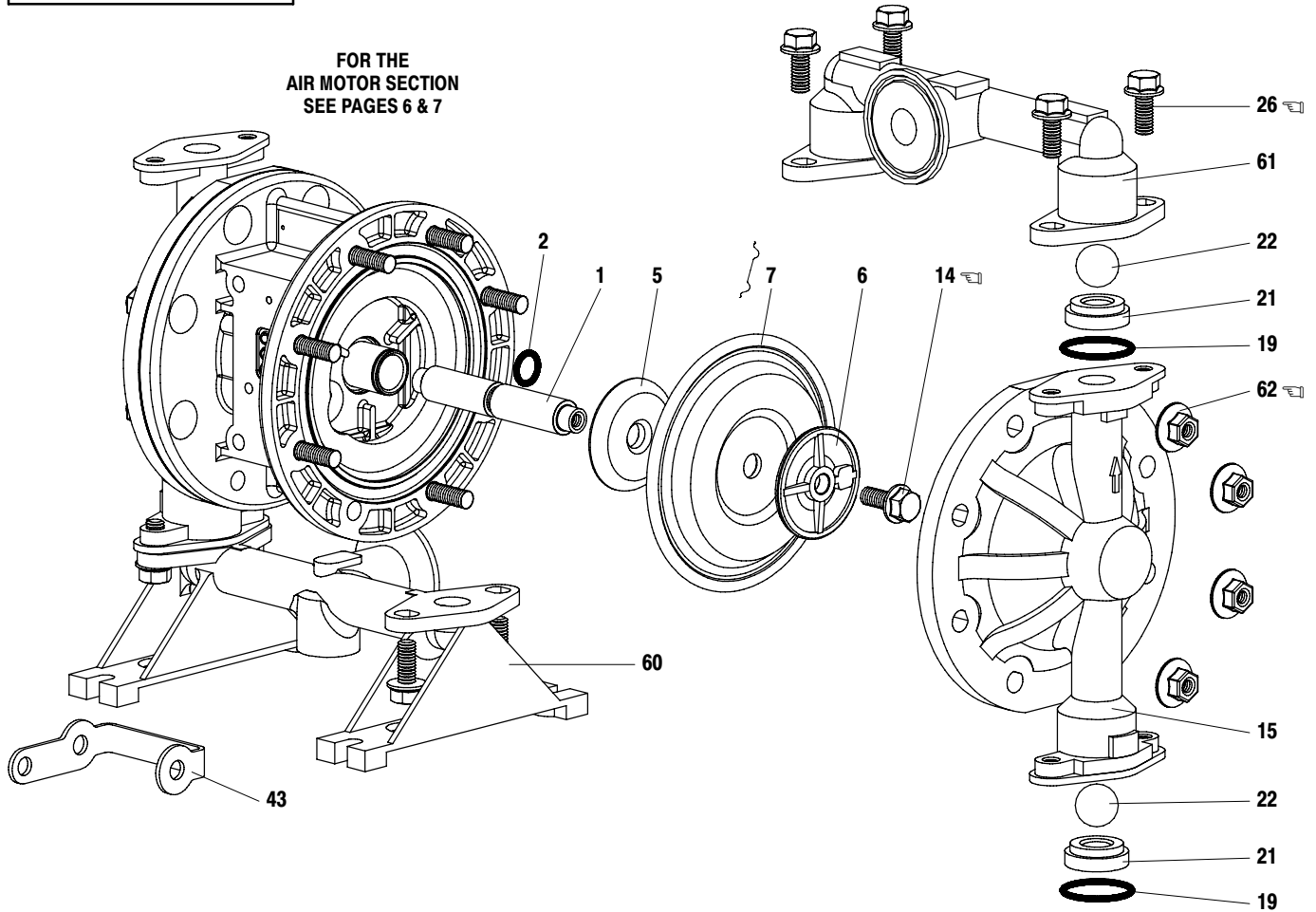

TORQUE REQUIREMENTS
NOTE: DO NOT OVERTIGHTEN FASTENERS
 (14) Bolt 95 - 105 in. lbs (10.7 - 11.9 Nm)
 (26) Bolts 50 - 60 in. lbs (5.6 - 6.8 Nm)
 (62) Fluid cap nuts 50 - 60 in. lbs (5.6 - 6.8 Nm), / alternately and evenly, then re-torque after initial run-in.

LUBRICATION / SEALANTS
 Apply Key-Lube (93706-1) to all "O" rings, "U" cups and mating parts.

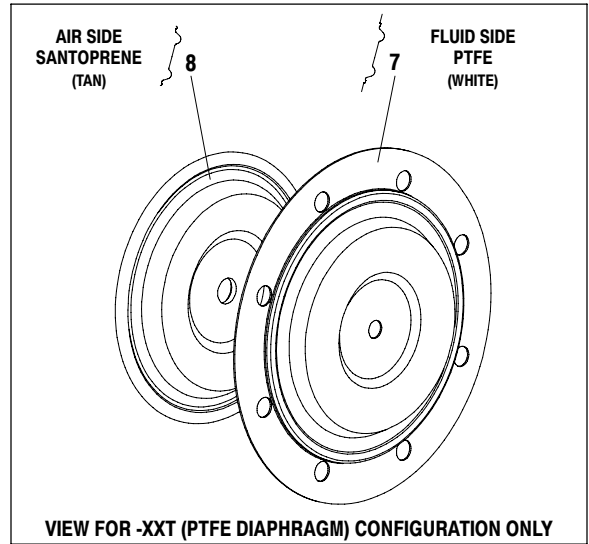

FIGURE 3

VIEW FOR -XXT (PTFE DIAPHRAGM) CONFIGURATION ONLY

PARTS LIST / PM05P-X AIR MOTOR SECTION

(✓) Indicates parts included in 637141 Air Section Repair Kit.

ITEM	DESCRIPTION (Size in inches)	Qty	Part No.	[Mtl]
101	Motor Body	(1)	93091	[P]
✓102	"O" Ring (3/32" x 1" o.d.)	(2)	Y325-117	[B]
□103	Sleeve	(1)	93087	[Bz]
□104	Snap Ring, (13/16")	(2)	37285	[C]
111	Spool	(1)	93085	[D]
118	Piston	(1)	93088	[C]
✓119	"O" Ring (1/8" x 3/4" o.d.)	(4)	93075	[U]
□120	Spacer	(3)	115959	[Z]
✓122	Snap Ring (1/2")	(2)	77802	[C]
129	Muffler	(1)	66972	[P]
129	Exhaust Cover (option)	(1)	93092	[PS]
✓130	Gasket	(1)	93107	[SY]
131	Bolt (5/16" - 18 x 1-1/4")	(16)	93095	[SS]
✓132	Gasket	(1)	93339-1	[B]

□ "Smart Parts" keep these items on hand in addition to the Service Kits for fast repair and reduction of down time.

ITEM	DESCRIPTION (Size in inches)	Qty	Part No.	[Mtl]
133	Washer (9/32" i.d.)	(4)	93096	[SS]
134	Cap Screw (1/4" - 20 x 5")	(4)	Y6-419-T	[SS]
135	Valve Block	(1)	93090	[P]
136	Plug	(1)	93086	[D]
✓137	"O" Ring (3/32" x 1-1/2" o.d.)	(1)	Y325-125	[B]
✓138	"U" Cup Packing (1/8" x 1" o.d.)	(1)	94395	[U]
✓139	"U" Cup Packing (1/8" x 1-7/16" o.d.)	(1)	96383	[B]
✓140	Valve Insert	(1)	93276	[CK]
✓141	Valve Plate	(1)	93275	[CK]
142	Washer	(2)	116038	[Z]
143	Plate	(2)	93089	[SS]
201	Muffler (option)	(1)	93110	[C]
✓	Keylube, "O" Ring Lubricant	(1)	93706-1	
	Keylube, 10 Pack		637175	

Note 1: A Major Valve Service Assembly is available separately which includes items: 111, 132, 135 - 141. Order part no 66362.

DIAPHRAGM PUMP SERVICE

GENERAL SERVICE NOTES:

- Inspect and replace old parts with new parts as necessary. Look for deep scratches on metallic surfaces, and nicks or cuts in "O" rings.
 - 7/16" wrench, 1/2" wrench, 7/16" socket, 1/2" socket, torque wrench (measuring inch pounds), "O" ring pick.

FLUID SECTION DISASSEMBLY

- Remove (61) top manifold.
- Remove (19) "O" rings, (21) seats and (22) balls.
- Remove (60) bottom manifold.
- Remove (19) "O" rings, (21) seats and (22) balls.
- Remove (15) fluid caps.
- Remove (14) bolt, (6) diaphragm washer, (7) or (7 / 8) diaphragms and (5) washer.
- Remove (1) connecting rod from air motor.
- Carefully remove remaining (14) bolt, (6) diaphragm washer, (7) or (7 / 8) diaphragms and (5) washer from (1) connecting rod. Do not mar surface of connecting rod.
- Remove (2) "O" ring from connecting rod.

MATERIAL CODE

[B] = Nitrile	[D] = Acetal	[SY] = Syn-Seal
[Bz] = Bronze	[P] = Polypropylene	[U] = Polyurethane
[C] = Carbon Steel	[PS] = Polyester	[Z] = Zinc
[CK] = Ceramic	[SS] = Stainless Steel	

FLUID SECTION REASSEMBLY

- Reassemble in reverse order.
- Lubricate (1) connecting rod and (2) "O" ring with Key-Lube or equivalent "O" ring lubricant.
- Install (5) washers with i.d. chamfer toward diaphragm.
- When replacing PTFE diaphragms, install the 93465 Santoprene diaphragm behind the PTFE diaphragm.

PARTS LIST / PM05P-X AIR MOTOR SECTION

TORQUE REQUIREMENTS
NOTE: DO NOT OVERTIGHTEN FASTENERS.
 (134) Torque to 15 - 20 in. lbs (1.7 - 2.3 Nm), wait 10 minutes, then re-torque to 15 - 20 in. lbs (1.7 - 2.3 Nm).

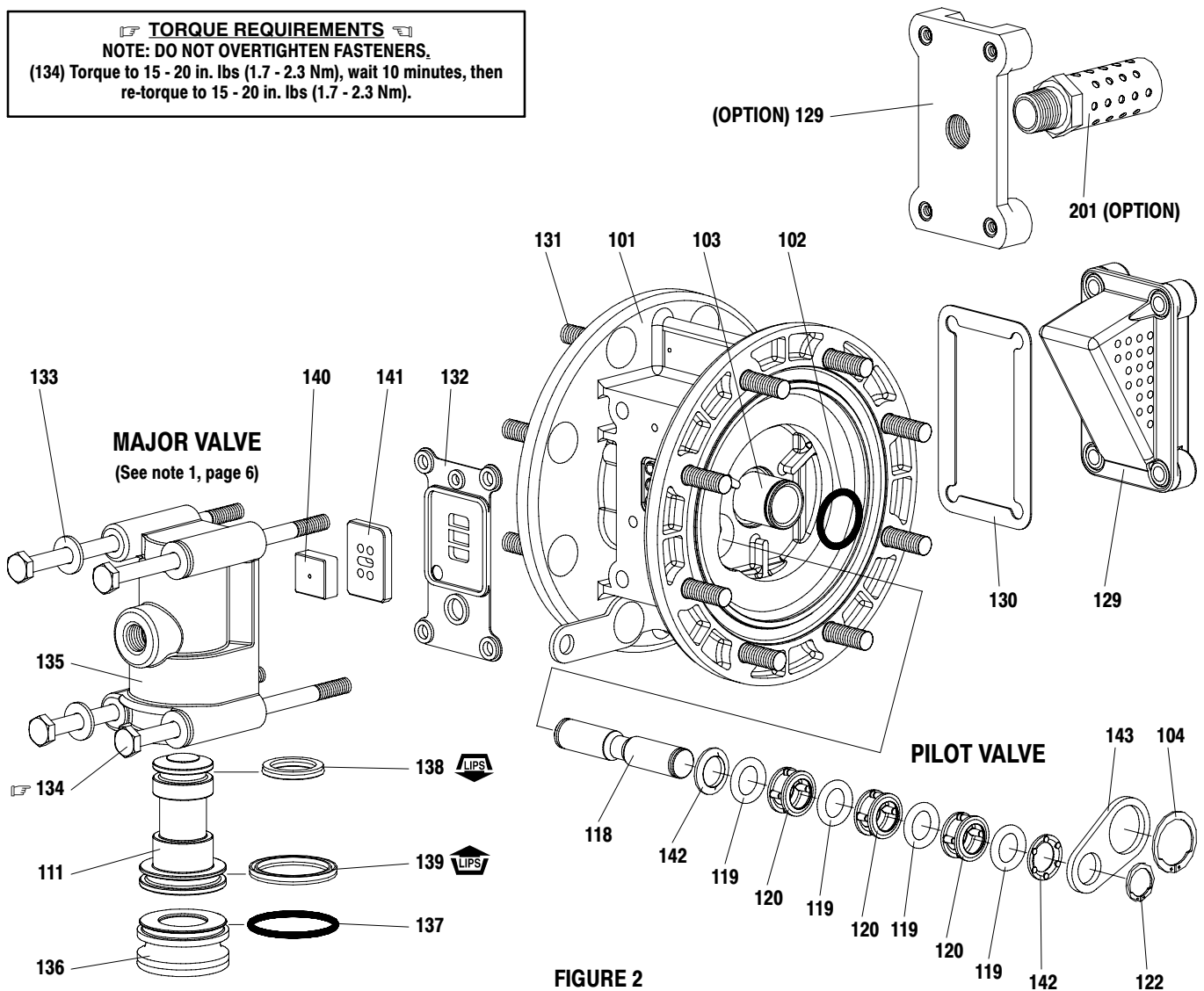

FIGURE 2

AIR MOTOR SECTION SERVICE

Service is divided into two parts - 1. Pilot Valve, 2. Major Valve.

- Air Motor Section Service is continued from Fluid Section repair.

PILOT VALVE DISASSEMBLY

1. Remove (122 and 104) snap rings.
2. Remove (143) plates.
3. Remove (103) sleeve and (102) "O" rings.
4. Remove (118) piston, (142) washers, (119) "O" rings and (120) spacers from (101) center body.

PILOT VALVE REASSEMBLY

1. Assemble (119) "O" rings, (120) spacers and (142) washers on (118) piston.
2. Insert the stack into the (101) body. Sleeve (103) may be used to assist pressing stack into body.
3. Install (103) sleeve and (102) "O" rings into (101) body.
4. Install (143) plates and (122 and 104) snap rings.

MAJOR VALVE DISASSEMBLY

1. Remove (129) muffler and (130) gasket.
2. Pull (135) valve block assembly from (101) motor body.
3. Remove (134) bolts, (133) washers and (132) gasket from (135) valve block.
4. Remove (141) valve plate and (140) valve insert.
5. Remove (136) plug and (111) spool.

MAJOR VALVE REASSEMBLY

1. Install new (139 and 138) "U" cups on (111) spool - **LIPS MUST FACE EACH OTHER.**
2. Insert (111) spool into (135) valve block.
3. Install (137) "O" ring on (136) plug, insert plug into (135) valve block.
4. Install (140) valve insert and (141) valve plate into (135) valve block. Note: Assemble (140) valve insert with "dished" side toward (141) valve plate. Assemble (141) valve plate with 2 identification dots toward (132) gasket.
5. Replace (132) gasket and install valve block assembly on (101) body.

TROUBLE SHOOTING

Product discharged from air exhaust.

- Check for diaphragm rupture.
- Check tightness of (14) bolt.

Air Bubbles in product discharge.

- Check connections of suction plumbing.
- Check "O" rings between intake manifold and fluid caps.
- Check tightness of (14) bolt.

Pump blows air out main exhaust when stalled on either stroke.

- Check "U" cups on (111) spool in major valve.
- Check (141) valve plate and (140) insert for wear.
- Check (103) sleeve and (2) "O" ring on diaphragm connecting rod.
- Check (119) "O" rings on (118) piston for wear.

Low output volume.

- Check air supply.
- Check for plugged outlet hose.
- For the pump to prime itself, it must be mounted in the vertical position so that the balls will check by gravity.
- Check for pump cavitation - suction pipe should be 1/2" minimum or larger if high viscosity fluids are being pumped. Suction hose must be non-collapsible type, capable of pulling a high vacuum.
- Check all joints on intake manifolds and suction connections. These must be airtight.
- Check for sticking or improperly seating check valves.
- If pump cycles at a high rate or runs erratically, check (119) piston "O" rings for wear.

DIMENSIONAL DATA

Dimensions shown are for reference only, they are shown in inches and millimeters (mm).

